

MAXIMACE

easier > faster > stronger >



INSTALLATION INFORMATION, August 21, 2015:

On some Blow Mold applications the **MaximACE** PET shock absorbers are short stroked and used as snubbers to just dampen the energy. The shock absorbers are used as dampers on all Sidel large mold applications and on the Sidel Heat Set machines stretch rod up application. The most common **MaximACE** PET shock absorber used for both applications is the PET 27M-3-NB. For both of these installations there is no standard shock absorber stick out measurement that can be offered, because there are too many application variables from machine to machine.

LARGE MOLD NEW INSTALLATION:

With the Mold closed and locked install the shock absorber; screw it in and note when the piston rod contacts the striking surface, then 2 additional full turns in and tighten the lock nut. Next test by opening and swiftly close the mold by hand to test for the desired damping. If too stiff and the mold will not lock, adjust the shock out slightly. Not stiff enough adjust the shock in slightly. Retest and when the desired damping is achieved, measure and note how far the shock is sticking out, and then set the rest of the stations with the same model numbered shock absorbers to the same measurement.

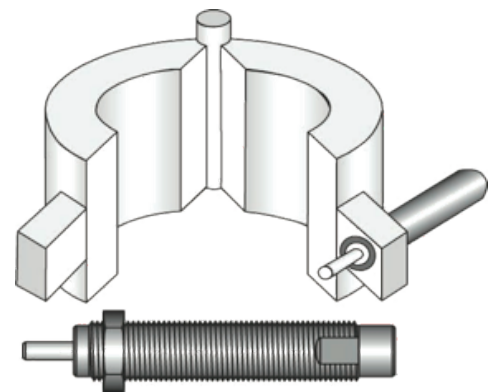

STRETCH ROD UP NEW INSTALLATION for Heat Set Machines:

With the stretch rod in the full up position, screw in the shock and note when the piston rod touches the striking surface, then screw in 2 additional full turns and tighten the lock nut. Next test buy cycling up and down to see if adequate damping is achieved. If a hard hit is noted at the beginning and you can visually see the deceleration, it may be set too stiff, then back the shock outward slightly and retest. If it goes through stroke and a hard hit noted at end of stroke or final set down position, then adjust the shock slightly inward. Next retest until there is no hard hit at beginning or end of stroke. **PLEASE NOTE:** When using only part of the stroke it sometimes can be a delicate balance to achieve. The final check is to make sure the override cam does not engage because of the shock absorber setting. If the override cam does engage you will have to slightly back the shock outward until there is no cam override action. Once this has been achieved, measure and note how far the shock is sticking out, and then set the rest of the stations with the same model numbered shock absorbers to the same measurement.

